

Hyperloop passenger transfer - not a normal station

Architects need to consider the structural limitations of the pod before designing the station.

Popular images show passengers using a conventional railway station to enter and exit the vacuum tube. Airports, car parks and railway stations are different because of the features of that transportation, and the Hyperloop 'station' needs to be designed to suit the unique challenges.

The passengers travel in a pressurised pod in the vacuum tube, and need to transfer into the atmosphere. There are two basic ways to do that:-

- Use a full-size airlock to move the pod and passengers out of the vacuum tube
- Leave the pod in the vacuum, and move the passengers out through an airlock door.

Side doors are structurally impossible

The image shows the most popular Hyperloop station concept, it looks deceptively simple, and allows a station layout like a normal train system.

But it ignores the technical challenges with operating in a vacuum, the extreme loads on doors, and the importance of eliminating leaks from the door seals.

The Hyperloop pod in a vacuum is **more like a spaceship than a train**, airlocks need to be taken very seriously. The large side doors in the image would be incapable of holding any pressure.

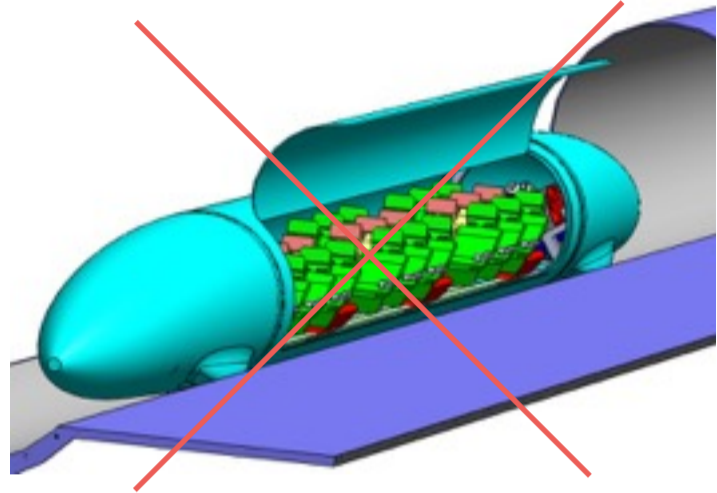

Extreme air pressure loading on the side door

Aircraft have very heavy and complex doors due to the internal pressure, and dangers of explosive de-compression. But Hyperloop will have 60% more internal pressure, 10 tonnes/sq m, and the side doors need to be much bigger. The door in the image above is 15 sq m, and it would have a force of 150 tonnes, about the same as 100 cars. The door, and the framing on the hull, would need to be massive to take these loads, greatly increasing the size, weight and complexity of the pod.

The problems of the side-door system

- Door loading of 150 tonnes, the weight of nearly 100 cars
- High risk of mechanical failure leading to explosive de-compression
- Large area of vacuum seals, subject to passenger interference
- The large cutaway in the pressure hull compromises its structure
- The whole pod must exit the airlocks, taking time and energy
- Passenger loading would be slow, requiring many platforms and a large station

Screw-in end door is the safe solution

Most pressure vessels are sealed by a circular screw thread, and the Hyperloop pressure hull should be the same.

The end door is locked with a multi-start thread, rather like a camera bayonet thread.

The twin sealing O-rings are simple and provide a secure vacuum seal.

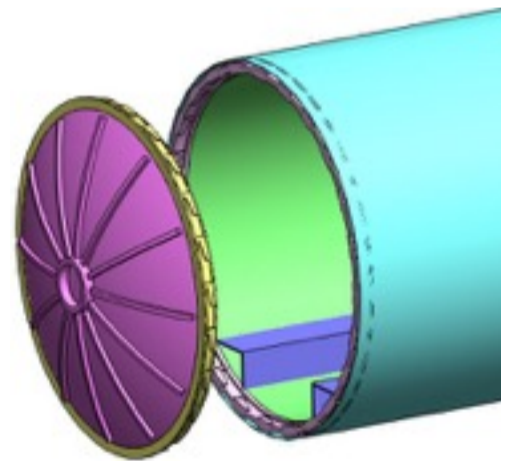

End door airlock requires different approach to passenger loading

The hull is too small for the passengers to walk along, so they cannot move to their seats.

The seats would need to roll out of the hull, to be accessed by the passengers. The concept of moving seating modules gives exciting possibilities for station design.